

SECTION A-A  
比例 2.5 : 1

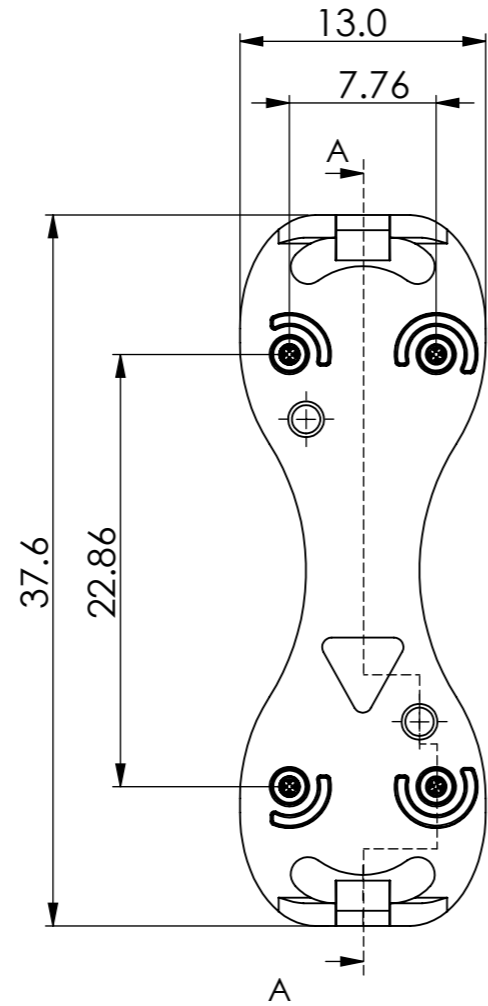

A

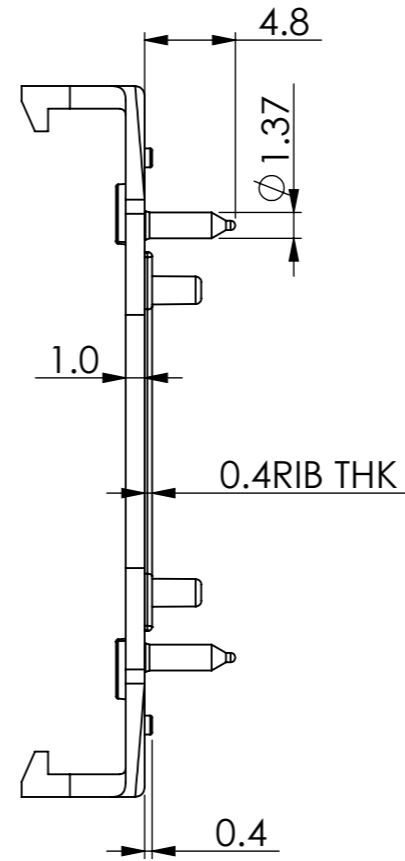

DETAIL B  
DETAIL 6 : 1

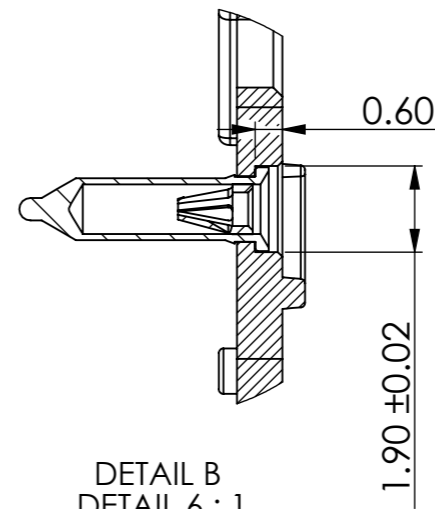
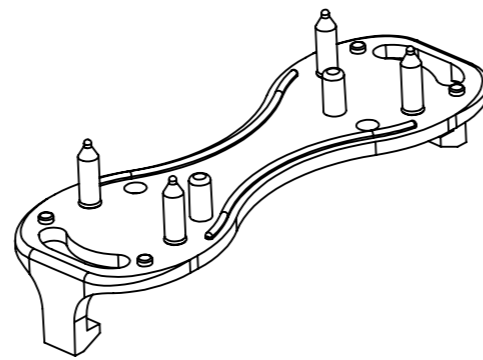
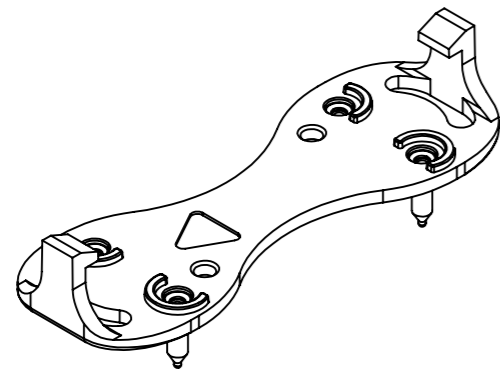
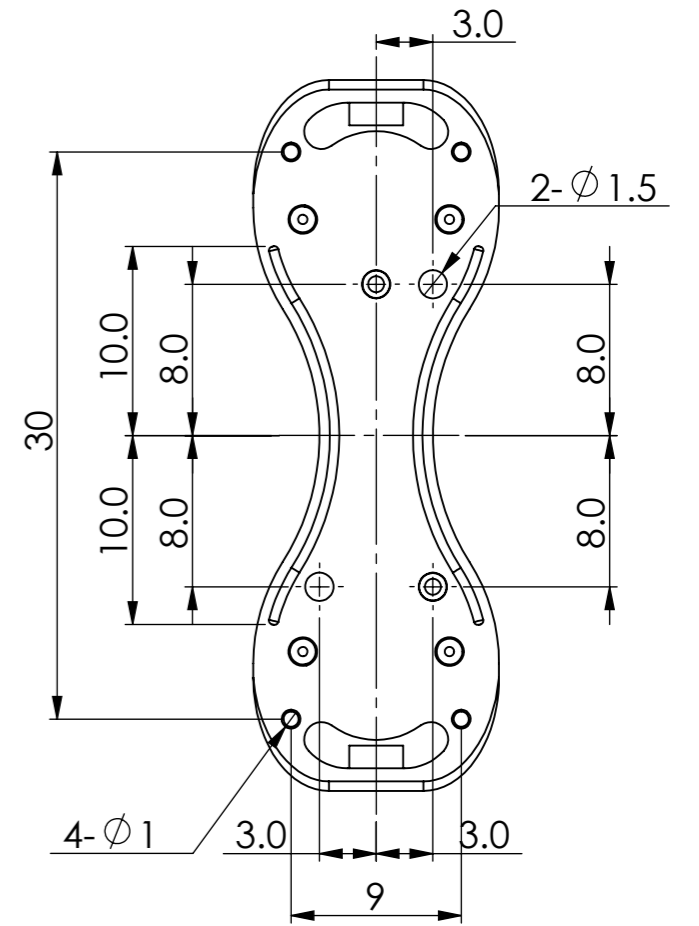

|      |          |             |            |          |                                |
|------|----------|-------------|------------|----------|--------------------------------|
| 3    | R050030  | Claw        | 4          | CU       | Plating<br>Ni50u",<br>Gold 1u" |
| 2    | R050020  | Solder pin  | 4          | CUZn     | Plating:<br>Ni80u",<br>Sn200u" |
| 1    | R0280001 | Base Module | 1          | PA66     |                                |
| Item | PartNo.  | Part name   | Quantities | Material | Remark                         |

|                   |               |                  |          |  |               |
|-------------------|---------------|------------------|----------|--|---------------|
| Drawing No.       | RFM28-05      | Revision         | A0       | Material   | Date of Issue |
| Product/Part Name | Reflow Module | Product/Part No. | RFM28-05 | JDE No.  | Size          |
| Project Title     | RFM28-05      | Unit             | mm       | Draw by  | Approve by    |
|                   |               |                  |          | Tolerance unless specified<br>Dimension in mm<br>x.x = +/- 0.10    x.xx = +/- 0.03<br>Angle in degree<br>x.x = +/- 1°    x.xx = +/- 0.5° |               |