

A (10:1)

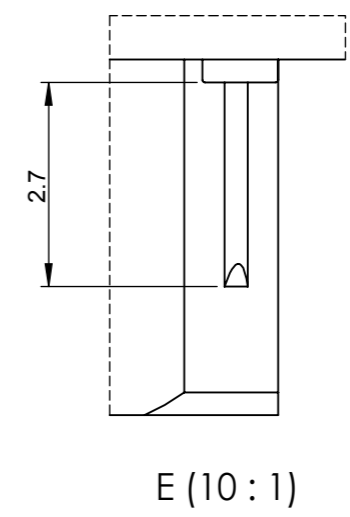

- SPECIFICATIONS:**
- Housing:**
 -Material:PC
 -Colour:Black
 -Hold force clips:85N max
- Shaft:**
 -Material:Stainless Steel
 -Axialforce(stake-on):150N max
 -Axial pull force:70N max
 -Radial force:12N max
 -External Torque: 40mNm max
 -Rotation Angle:315° max
- EI confacts:**
 -Material:Copper Alloy
 -Coil:el.resistance 280Ω
 Undim. Radio R0.05~0.10
 Undim. Chamfered edges 0.30x45°

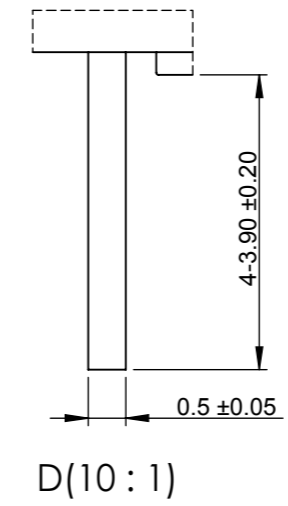
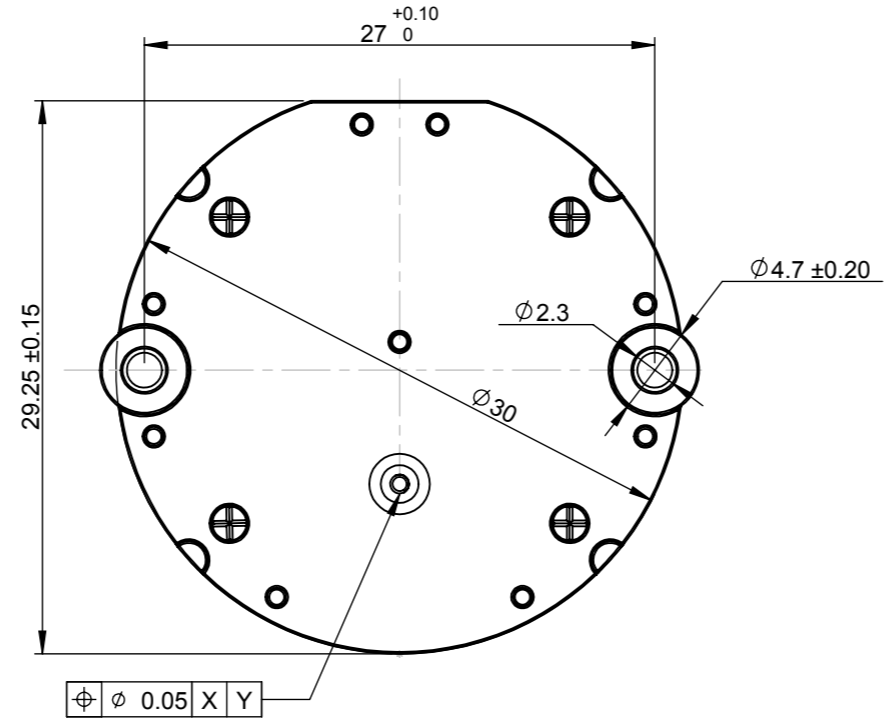
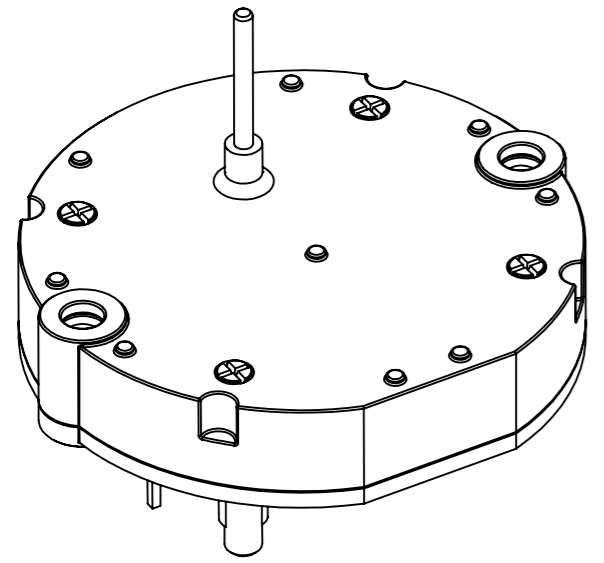

$\phi 0.05$ X Y

Drawing No. VID29-02	Revision A0	Material	Date of Issue 2022.05.18
Product/Part Name Stepper Motor	Product/Part No. VID29-02	JDE No.	Size A3
Project Title VID29-02	Unit mm	Approve by	
		Tolerance unless specified Dimension in mm x.x = +/- 0.10 x.xx = +/- 0.03 Angle in degree x.x = +/- 1° x.xx = +/- 0.5°	